

SSRMAN-1B (TP) SERIES USERS MANUAL

SOLID-STATE RELAY INTELLIGENT BURST FIRING / TIME PROPORTIONING CONTROL

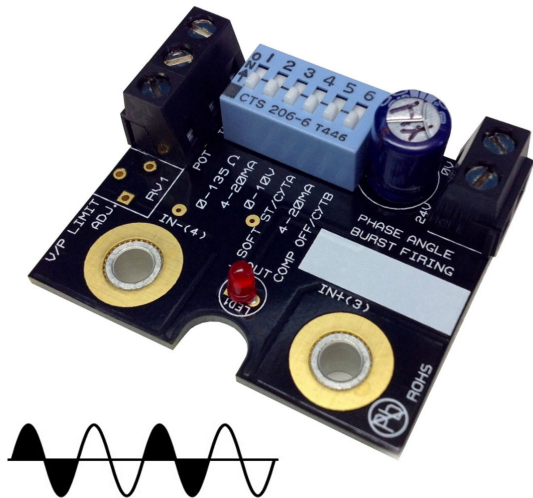

TP A Series Proportional Output (Burst-Fire)
Solid State Relay Power Controller

TABLE OF CONTENTS

1.	Ordering Codes	2
2.	Description	2
2.1	Features	3
3.	Installation / Safety Information	3
3.1	Solid State Relay Installation	3
3.2	Mounting Instructions	4
3.3	Electrical Connections	4
3.3.1	Internal Diagram	4
3.4	Limited Warranty	5
4.	Operation	5
4.1	Power Supply	5
4.2	24V Power Fusing	5
4.3	Command Input	5
4.3.1	Input Fail-safe Protection	5
4.4	Cycle Times	6
4.5	Power Limit	6
4.5.1	Power Limit Adjustment Procedure	6
4.6	Configuration Dipswitch	6
4.7	Control Output	7
4.8	Output LED	7
4.9	Three Phase Operation	8
4.9.1	Three Phase Operation – Cycle Times	8
4.10	Wiring Multiple Units	8
4.10.1	Connecting Power & Commands In Parallel	8
5.	Electrical Specifications	9
6.	Mechanical Dimensions	9
7.	Contact Information	9
8.	WIRING DIAGRAM (4-20mA, 0-5V, 0-10V Inputs)	10
9.	WIRING DIAGRAM (Potentiometer Input)	10
10.	WIRING DIAGRAM (0-135 Ohm Input)	11
11.	WIRING DIAGRAM 3 PHASE DELTA CONNECTION	11
12.	WIRING DIAGRAM 3 PHASE WYE	12

1. Ordering Codes

Part#	Description	Inputs
SSRMAN-1B	SSR Mount Burst Firing Control Module, Volts, mA Input, Pot	0-10V, 0-5V, 2-10V, 1-5V, 4-20mA, 0-20mA, Potentiometer
SSRMAN-1B-135	SSR Mount Burst Firing Control Module, 0-135Ω Input, 24VAC Power Only	0-135Ω
SSRMAN-1B-REV	Reverse Acting Output Option	0-10V, 0-5V, 2-10V, 1-5V, 4-20mA, 0-20mA, Potentiometer
SSRMAN-1B-PL	SSR Mount Burst Firing Control with power limit option	0-10V, 0-5V, 2-10V, 1-5V, 4-20mA, 0-20mA, Potentiometer

2. Description

The SSRMAN-1B is a burst firing (time proportioning) control module designed for use with industry standard zero-cross or random fire SSRs (solid-state relays). The module mounts directly on the SSR's input screws and operates by varying the duty cycle of the SSR's control input. The power delivered to the load is proportional to the command input signal.

2.1 Features

- Command input accepts 4-20mA, 0-10V, 0-5V, 0-135 Ω , Potentiometer
- Configurable for 4 different cycle times
- Drives multiple solid-state relays (SSRs)
- Small (1.75x1.40") module mounts directly to the SSR input terminals
- Fits under finger-safe covers
- LED output indicator
- Adjustable Power Limit (-PL) Option
- Single phase and three-phase control

3. Installation / Safety Information

Responsibility for determining suitability for use in any application / equipment lies solely on the purchaser, OEM and end user. Suitability for use in your application is determined by applicable standards such as UL, cUL and CE, and the completed system involving this component should be tested to those standards.



WARNING: FIRE HAZARD!! Even quality electronic components can fail! Ensure that separate (redundant) over temperature and short circuit protection is installed to disconnect power to the solid-state relay if a fault occurs.



WARNING: HIGH VOLTAGE!! The SSRMAN is designed to be installed on a solid-state relay connected to a high voltage AC source. This product must be installed in a grounded enclosure by a qualified electrician in accordance with applicable local and national codes, including NEC and other applicable codes. A safety interlock should be installed on the access door to disconnect power before gaining access to the device.

3.1 Solid State Relay Installation

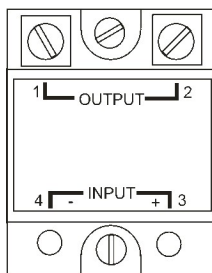

Make sure that the voltage and current ratings of the solid-state relay (SSR) are sized correctly for the load, otherwise a hazardous condition such as over-heating, failure of the SSR, fire or explosion may result. Contact HBCcontrols for more details.



The SSR must be mounted to a heat sink as per the SSR manufacturers requirements, otherwise a hazardous condition such as over-heating, failure of the SSR, fire or explosion may result. Contact HBCcontrols for more details.

3.2 Mounting Instructions

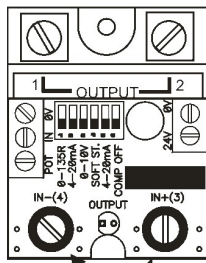

SSRMAN SHOULD BE ORIENTED AS SHOWN AND SCREWED TIGHT TO INPUT TERMINALS

The SSRMAN mounts directly to the control input terminals of an SSR using two #6-32 screws (or M4 screws on European SSRs). Some relays have short input screws and longer screws will be required to reach through the mounting holes of the SSRMAN.

Be sure to observe the correct polarity when mounting the module (module should be positioned over the SSR). The module should sit firmly on top of the SSR when the screws are tightened.

3.3 Electrical Connections

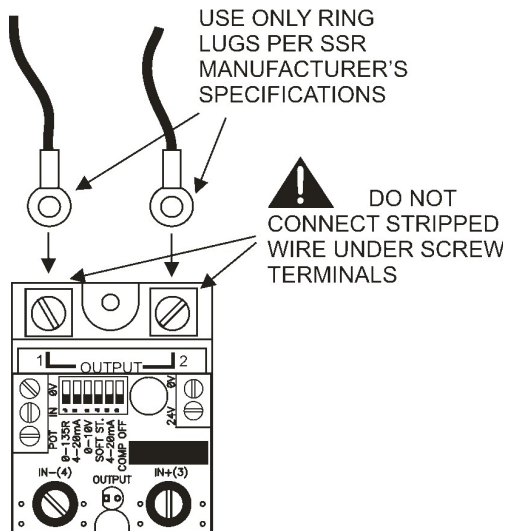

See the WIRING DIAGRAMS at the end of this document. Make sure the module ordered is the correct module for the application before wiring.

Before wiring the module, all Dip Switch settings for the command input and special features should be setup properly per the Dipswitch Configuration section.

The terminal blocks on the sides of the SSRMAN for connecting 24V Power and the command signal can accept 16-30 AWG wire.

3.3.1 Internal Diagram

Please reference the internal diagram below to ensure that the system wiring will be compatible with the control module.

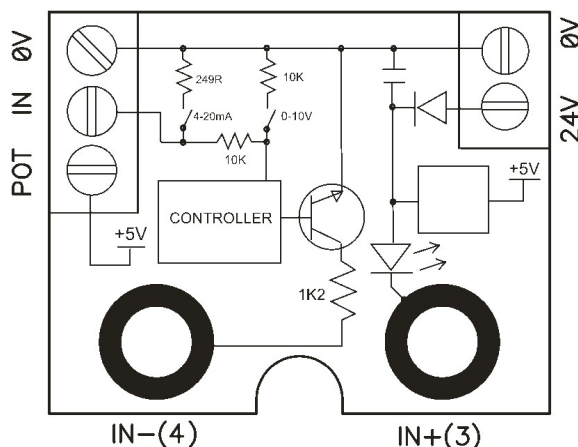

3.4 Limited Warranty

HBControls, Inc. warrants this product to be free from defect in workmanship and materials for a period of two (2) years from the date of purchase.

1. Should unit malfunction, return it to the factory. If found to be defective, it will be repaired or replaced at no charge.
2. There are no user serviceable parts on this unit. This warranty is void if the unit shows evidence of being tampered with or subjected to excessive heat, moisture, corrosion, or other misuse / misapplication.
3. Components which wear or damage with misuse are excluded (e.g. relays).
4. HBControls, Inc. shall not be responsible for any damage or losses however caused, which may be experienced as a result of the installation or use of this product. HBControls, Inc. liability for any breach of this agreement shall not exceed the purchase price paid E. & O.E.

4. Operation

4.1 Power Supply

The SSRMAN-1B power requirement is 24V AC +/-15% 47-63Hz, 24VDC +30/-10%.

4.2 24V Power Fusing

Fusing may be accomplished by fusing each module separately or fusing groups of the modules with either primary or secondary fusing. The current draw of each SSRMAN-1B is 65mA max.

4.3 Command Input

The SSRMAN-1B can accept 4-20mA, 0-10V, 0-5V, and Potentiometer inputs. The SSRMAN-1B-135 can only accept a 0-135 Ω input and must be used with 24VAC Power. All command inputs are not isolated from the 24V power input; they share a common ground. The type of command input can be configured via the dipswitch. The default setting is 0-5V/potentiometer.

When wiring multiple SSRMAN-1Bs together, follow the guidelines in the Wiring Multiple SSRMAN-1Bs section.

Any leg of the command input can tolerate shorts to the (0V) input. Connecting the 24V power to the command input will damage to the unit.

When 4-20mA is selected via the dipswitch, a 249 Ohm shunt resistor is present at the command input between the 0V and IN terminals. Be sure not to exceed 20mA DC on the input as damage to the unit may result. If the command input is wired to a 0-20mA or 4-20mA output of another device, the 0V terminal must remain at the same potential as the negative lead of the current output from the other device, otherwise damage to the SSRMAN may result.

4.3.1 Input Fail-safe Protection

If the signal sent to the SSRMAN-1B command input should become electrically open, the control output will be forced to an off or less than 5% output power state.

4.4 Cycle Times

The SSRMAN-1B has 4 available cycle times; 200mS, 1S, 10S, and 100S.

Generally, the cycle time should be chosen based on the mass of the load to be controlled; the larger the load mass, the longer the cycle time can be. Generally, it is best to choose the longest cycle time that can be used without causing process ripple.

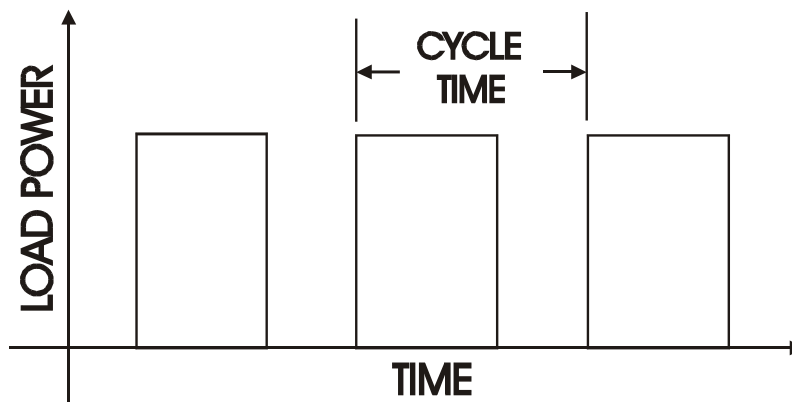

4.5 Power Limit

The Power Limit option can be ordered as SSRMAN-1B-PL. The Power Limit feature is used to limit the average power delivered to the load. The power limit is adjustable via a potentiometer located just below the input terminal block. The Power limit feature is only available for use with 24VAC Power.

4.5.1 Power Limit Adjustment Procedure

The Power Limit is adjustable from 10% to 100% of the max load power (0-100% for 1-5V or 4-20mA ranges). Setting the Power Limit potentiometer halfway corresponds to a power limit of approximately 55%. With the command input set to approximately 100% (on startup) turn the pot fully CCW. Then adjust the pot CW until the desired output power is achieved.

4.6 Configuration Dipswitch

The configuration dipswitch is used for setting up the command input and the cycle time. Using the point of a pen or similar device, gently push the switch up for on and down for off according to the setup outlined in the table below.

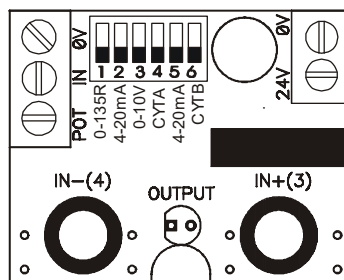

Command Input	1	2	3	5
0-5V (Default)	OFF	OFF	OFF	OFF
Potentiometer	OFF	OFF	OFF	OFF
0-10V	OFF	OFF	ON	OFF

4-20mA	OFF	ON	OFF	ON
1-5V	OFF	OFF	OFF	ON
2-10V	OFF	OFF	ON	ON
0-135Ω*	ON	OFF	OFF	OFF

*Module must be ordered as SSRMAN-1B-135 for 0-135Ω input support.

135 Ω input support is only useable with 24VAC Power.

Cycle Time	4	6
200mS	OFF	OFF
1 Second	OFF	ON
10 Seconds	ON	OFF
100 Seconds	ON	ON

4.7 Control Output

The SSRMAN-1B SSR output drive is a DC pulsed, current limited drive signal of 10V/15mA (24VAC power) or 10V/9.5mA (24VDC power). This is more than enough current for driving most 3-32V standard SSRs, however it is still important to review the data sheet for the SSR you would like to use for compatibility with the output drive of the SSRMAN-1B. The control output can tolerate a momentary direct short. The following graph will allow you to verify the SSR's compatibility with the SSRMAN-1B over wide input voltage variations.

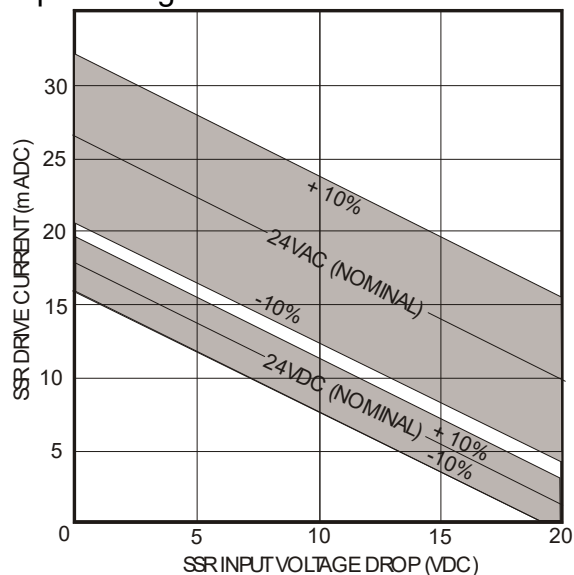

SSRMAN-1B Output Drive Current vs. SSR Input Voltage Drop

4.8 Output LED

The red output LED on the SSRMAN-1B will illuminate when the output is on. The output LED is wired in series with the SSR's input. If there is a poor connection on the SSR input terminals or a problem with the SSR's Input, the output LED will not illuminate.

4.9 Three Phase Operation

One SSRMAN-1B can be used to control two poles of a three-phase load using two SSRs with their control inputs wired in parallel. The Module should be wired as shown in the three phase wiring diagrams sections. The Control Output section should be reviewed to make sure that the total input current requirements of the two SSRs can be achieved with the SSRMAN-1B.

4.9.1 Three-Phase Operation – Cycle Times

When using the SSRMAN-1B to control three-phase loads, the cycle time should be set for at least one second, and preferably set to 10 or 100 seconds. This will maximize the control resolution and minimize any load imbalances.

4.10 Wiring Multiple Units

If more than one SSRMAN-1B is to be used from a non-isolated or common command signals:

1. A common power transformer can be shared. If the input selected is 0-10V or 0-5V, the inputs should be wired in parallel.
2. If multiple units must be powered from one power transformer and 4-20mA input is selected, one module should be set for 4-20mA, and the remaining modules should be set for 1-5V.
3. If the command is 4-20mA and the command inputs are to be wired in series, a separate power transformer for each module is required to isolate the inputs.

4.10.1 Connecting Power & Commands in Parallel

When multiple SSRMAN-1B power inputs and commands are wired in parallel, all of the 0V terminals must be connected together follows:

Power:	Command:
0V-----0V-----0V----->	0V-----0V-----0V----->
24V---24V---24V---->	IN-----IN-----IN----->

No crossing of the power input feed or command signal is permitted. If for some reason the power should become crossed, it will cause a direct short in the system. If properly fused, the fuse will blow and the SSRMAN-1B will not be damaged. If the command inputs are wired improperly, damage to SSRMAN-1B can result.

We do not guarantee operation of the SSRMAN-1B with any other manufacturer's SSR control module. Using them in the same circuit may cause either module to be damaged.

5. Electrical Specifications

Command Inputs	4-20mA, 0-10V, 0-5V, 0-135 Ω , Pot, 0-135 Ω
Input Impedance	10K Ω (0-10V), 250 Ω (4-20mA), 100K Ω (0-5V)
0-135 Ω Excitation Current	13mA max
Control Output	SSR Drive, nominally 10V at 15mA (24VAC)
10V at 9.5mA (24VDC)	
Output Resolution	0.5% for 4-20mA, 0-5V, pot and 0-10V. 1% for 0-135 Ω
Output Linearity	1.5% for 4-20mA, 0-5V, pot and 0-10V. 5% for 0-135 Ω
Power Limit Range	10-100% of max load power.
External Potentiometer Res.	1K Ω -25K Ω
Ambient Temperature Range	0 to 60 $^{\circ}$ C
Power Supply	24VAC +15/-15%, 24VDC +30%/-10%
Power Consumption	65mA (Power consumption 1.6W MAX)
Line Frequency Range	(24VAC power) 47-63 Hz
Terminal Block wire Gauge	16-30 AWG
Terminal Block Material	Polyamide 6.6 UL 94 V-0, Black

6. Mechanical Dimensions

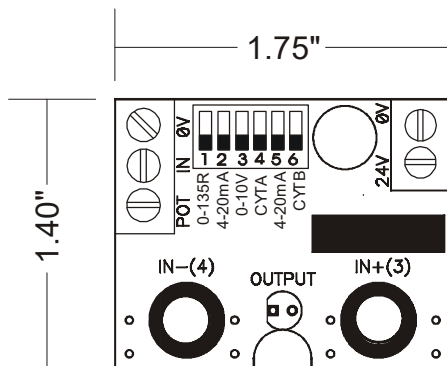

Max Height is 0.6"

7. Contact Information

HBControls, Inc
 800-879-7918
www.hbcontrols.com

8. WIRING DIAGRAM (4-20mA, 0-5V, 0-10V Inputs)

SSRMAN-1B WIRING DIAGRAM (4-20mA, 0-5V, 0-10V INPUT)

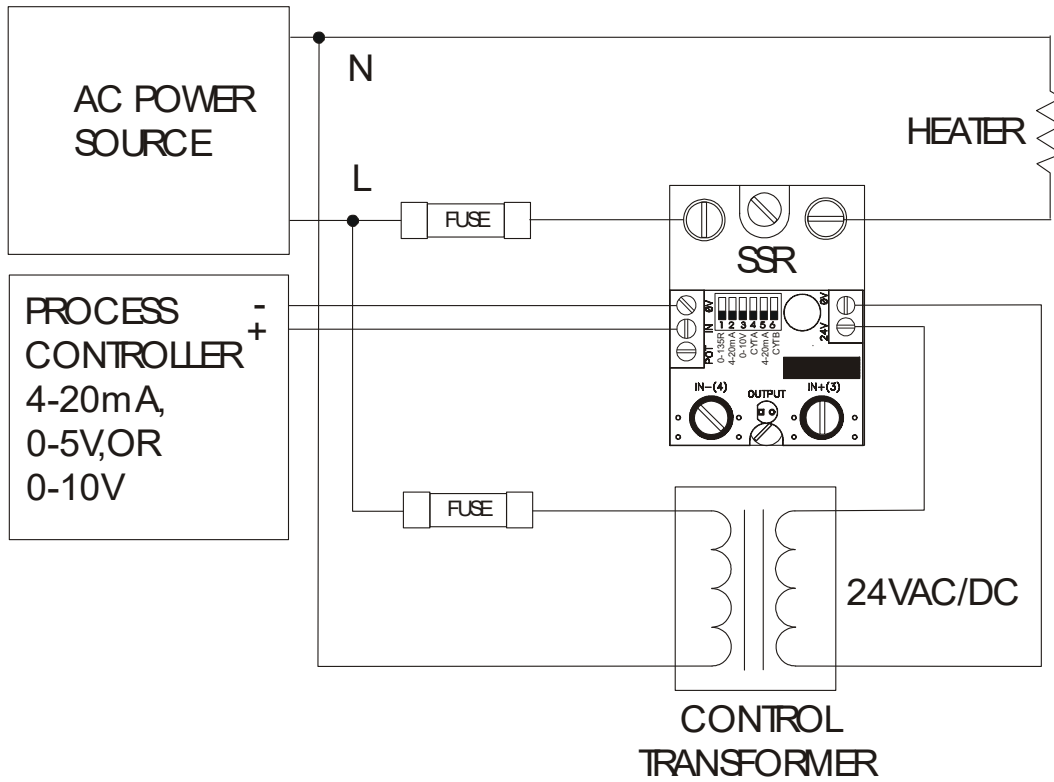

9. WIRING DIAGRAM (Potentiometer Input)

SSRMAN-1B WIRING DIAGRAM (POTENTIOMETER INPUT)

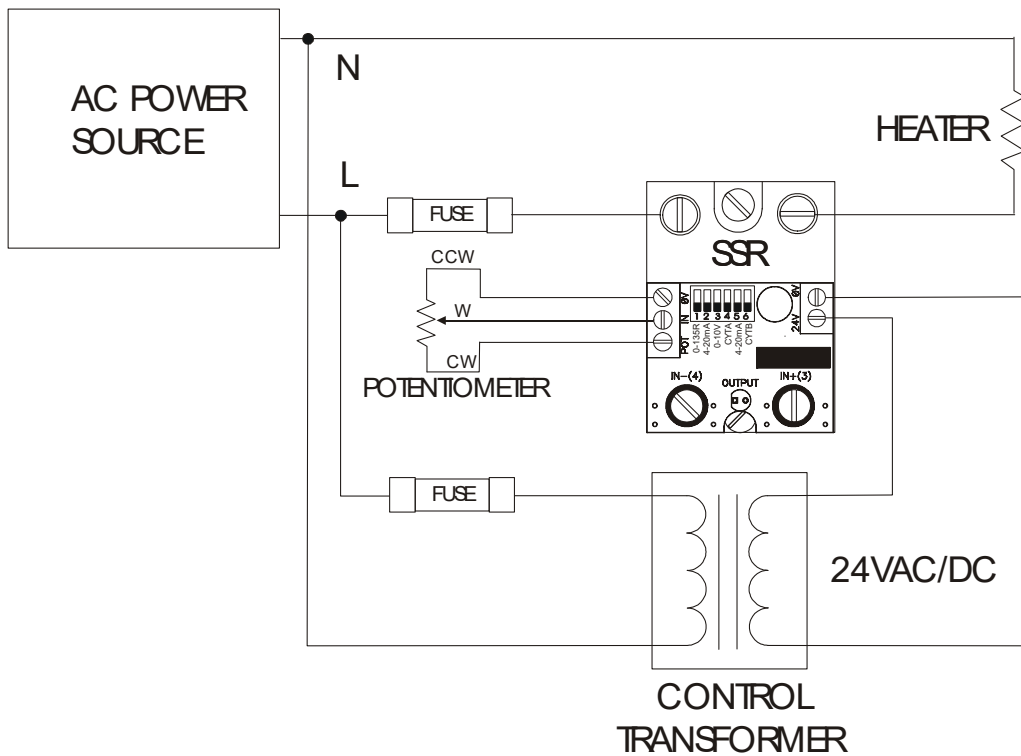

10. WIRING DIAGRAM (0-135 Ohm Input)

SSRMAN-1B WIRING DIAGRAM (0-135 Ohm Input)

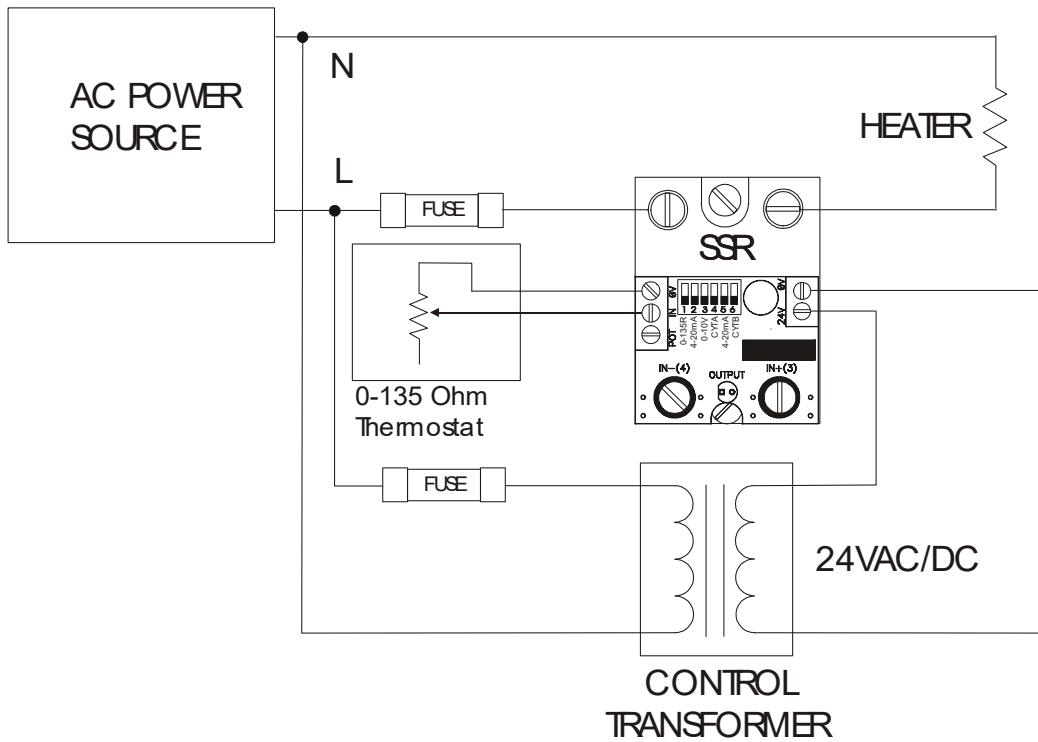

11. WIRING DIAGRAM 3 PHASE DELTA CONNECTION

3 PHASE DELTA CONNECTION
SSRMAN-1B LOAD WIRING DIAGRAM

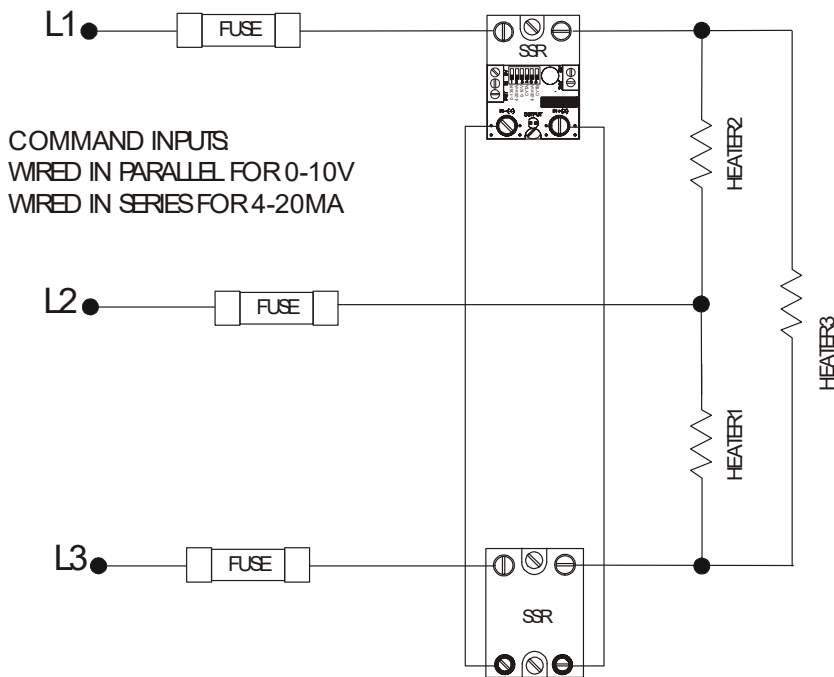

12. WIRING DIAGRAM 3 PHASE WYE

3 PHASE WYE CONNECTION SSRMAN-1B LOAD WIRING DIAGRAM

