

## **LPC USERS MANUAL**

### **SSR INTELLIGENT PHASE ANGLE CONTROL MODULE**



## TABLE OF CONTENTS

1.	Ordering Codes .....	2
2.	Description.....	3
2.1	Features.....	3
3.	Installation .....	3
3.1	Mounting Instructions.....	3
3.2	Electrical Connections .....	3
4.	Operation.....	4
4.1	Power Supply.....	4
4.2	24V Power Fusing .....	4
4.3	Command Input .....	4
4.4	PWM Command Input .....	4
4.4.1	Input Fail-safe Protection .....	4
4.5	Line Voltage Compensation .....	4
4.6	Soft Start.....	4
4.7	Voltage Limit .....	5
4.7.1	Voltage Limit Adjustment Procedure .....	5
4.8	Configuration Dipswitch.....	5
4.9	Control Output .....	6
4.10	Output LED .....	7
4.11	Three Phase Operation .....	7
4.11.1	Three Phase Special Wiring Considerations .....	7
4.11.2	Three Phase Wiring of Command Inputs.....	7
4.12	Wiring Multiple Units in Single Phase Applications .....	7
4.12.1	Connecting Power & Commands In Parallel.....	8
5.	Electrical Specifications.....	8
6.	Mechanical Dimensions .....	8
7.	Contact Information .....	9
8.	WIRING DIAGRAM (4-20mA, 0-5V, 0-10V Inputs).....	9
9.	WIRING DIAGRAM (Potentiometer Input) .....	10
10.	WIRING DIAGRAM (0-135 Ohm Input) .....	10
11.	WIRING DIAGRAM (PWM Input).....	11
12.	WIRING DIAGRAM 3 PHASE 4 WIRE Y CONNECTION .....	11
13.	WIRING DIAGRAM 3 PHASE INSIDE DELTA.....	12

### 1. Ordering Codes

Part#	Description	Inputs
<b>LPC</b>	SSR Mount Phase Angle Control Module, Volts, mA Input, Pot	0-10V, 0-5V, 2-10V, 1-5V, 4-20mA, 0-20mA, Potentiometer
<b>LPC-VL</b>	SSR Mount Phase Angle Control Module, Volts, mA Input, Pot, Voltage Limit Option	0-10V, 0-5V, 2-10V, 1-5V, 4-20mA, 0-20mA, Potentiometer
<b>LPC-135</b>	SSR Mount Phase Angle Control Module, 0-135Ω Input	0-135Ω
<b>LPC-REV</b>	Reverse Acting Output Option	0-10V, 0-5V, 2-10V, 1-5V, 4-20mA, 0-20mA, Potentiometer
<b>LPC-PWM</b>	SSR Mount Phase Angle Control Module, PWM Input	PWM (time proportioning logic input)
<b>LPC-XSS</b>	X Second Soft Start Time, where X is choice of 2-18 seconds Default is 20 Seconds when -XSS is omitted	0-10V, 0-5V, 2-10V, 1-5V, 4-20mA, 0-20mA, Potentiometer

## 2. Description

The LPC is a phase angle control module designed for use with standard footprint random fire SSRs (Solid State Relays). The module mounts directly on the SSR's input screws. The module operates by varying the firing point of the SSR's input. The power delivered to the load is proportional to the command input signal. The LPC will not operate correctly with zero cross fired SSRs.

### 2.1 Features

- Provides true linear power output phase angle control
- Small (1.75x1.40") module mounts on the input terminals of an inexpensive SSR
- Command input accepts 4-20mA, 0-10V, 0-5V, 0-135  $\Omega$ , Pot, PWM
- Configurable line voltage compensation increases stability of your process
- Configurable soft start for high inrush loads
- Automatic 50/60Hz operation
- Adjustable Voltage Limit (-VL) Option
- Drives multiple solid state relays
- Single phase and three phase control

## 3. Installation



**WARNING: FIRE HAZARD!!** Even quality electronic components CAN FAIL KEEPING FULL POWER ON! Provide a SEPARATE (redundant) OVER TEMPERATURE SHUTDOWN DEVICE to switch the power off if safe temperatures are exceeded.



**WARNING: HIGH VOLTAGE!!** This control is installed on a Solid State Relay with high voltage on it. This control must be installed in a GROUNDED enclosure by a qualified electrician in accordance with applicable local and national codes including NEC and other applicable codes. Provide a safety interlock on the door to remove power before gaining access to the device.

### 3.1 Mounting Instructions

The LPC mounts directly to the control input terminals of an SSR. Some relays have short input screws and longer screws will be required to reach through the contacts on the LPC. Be sure to observe the correct polarity when mounting the module (module should be positioned over the SSR). The module should sit firmly on top of the SSR when the screws are tightened.

### 3.2 Electrical Connections

See the WIRING DIAGRAMS at the end of this document. Make sure the module ordered is the correct module for the application before wiring.

Before wiring the module all Dip Switch settings for the command input and special features should be setup properly per the Dipswitch Configuration Section

## 4. Operation

### 4.1 Power Supply

The LPC power requirement is 24V AC +/-15% 47-63Hz. The module will not operate from a 24VDC power supply since it relies on the 24VAC supply for synchronization to the AC line.

### 4.2 24V Power Fusing

Fusing may be accomplished by fusing each module separately or fusing groups of the modules with either primary or secondary fusing. The current draw of each LPC is 65mA max.

### 4.3 Command Input

The LPC can accept 4-20mA, 0-10V, 0-5V, and Potentiometer and PWM inputs. The LPC-135 can only accept 0-135  $\Omega$  inputs and the LPC-PWM can only accept PWM inputs. Command inputs are not isolated from the 24VAC power Input. The type of command input can be configured via the dipswitch. The default setting is 0-5V/potentiometer.

When wiring multiple LPC's together, follow the guidelines in the Wiring Multiple LPCs section.

Any leg of the command input can tolerate shorts to the (0V) input. Connecting the 24V AC power to the command input will cause damage to the unit.

### 4.4 PWM Command Input

The LPC's PWM Command input is designed to accept a signal from a PLC or a process/temperature controller's SSR drive output. This logic signal is used generate a command setpoint. The LPC can accept logic signals ranging from 5-30VDC.

#### 4.4.1 Input Fail-safe Protection

If the signal sent to the LPC's command input should become electrically open the control output will be forced to an off state.

### 4.5 Line Voltage Compensation

The LPC's line voltage compensation keeps the power constant on the load as the line voltage changes. The line voltage is measured via the 24VAC power applied to the LPC module. To use the line voltage compensation feature properly, the 24VAC power transformer should be fed from the same mains as the load circuit to be controlled as per the wiring diagrams at the end of this document. Line voltage compensation can be enabled or disabled using the configuration dipswitch. The default setting is enabled (switch # 6 is OFF). To disable the Line Voltage Compensation, set switch # 6 to the ON position.

### 4.6 Soft Start

The soft start feature ramps up to the command value over a period of approximately 20 seconds. The soft start time resets if the command value goes to zero (less than 4% of the input range) or power is cycled. Soft start is useful on high inrush heaters such as Quartz, Molybdenum, Tungsten, or Graphite heaters.

Soft Start can be set on or off using the configuration dipswitch. The default setting is off. Soft Start Times below 20 seconds are available and can be ordered by adding a -XSS to the ordering code where X is the time in seconds.

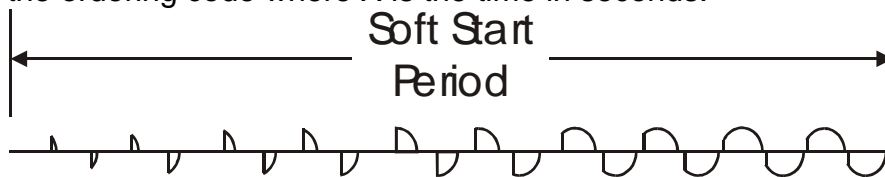

*The Soft Start ramps the voltage up slowly over the soft start period.*

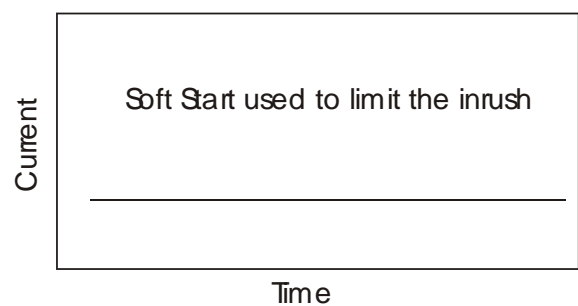
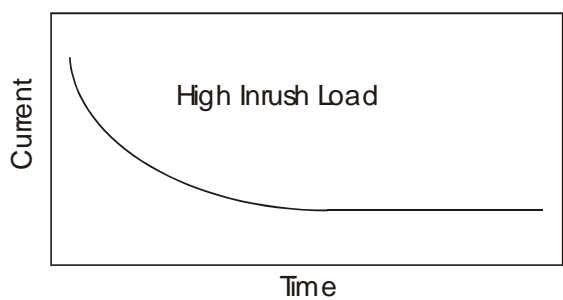

## 4.7 Voltage Limit

The Voltage Limit option can be ordered as LPC-VL. The Voltage Limit feature is used in conjunction with the line voltage compensation feature to limit the actual voltage delivered to the load. The voltage limit is adjustable via a potentiometer located just below the input terminal block. For this feature to work properly, line voltage compensation must be turned on and the power transformer for the LPC must be connected to the same mains as the load power is connected to.

### 4.7.1 Voltage Limit Adjustment Procedure

The Voltage Limit is adjustable from 5% to 100% of the max load voltage. Setting the Voltage Limit potentiometer half way corresponds to a power limit of approximately 55% or a voltage limit of 70% of the max load voltage. The best way to set the voltage limit is using a voltmeter connected across the load. With the command input set to approximately 100% (on startup) turn the pot fully CCW. Then just turn the pot CW until the desired output voltage is achieved. For this feature to work as a true voltage limit, it is important that the Line Voltage Compensation be enabled (this is the OFF position of switch # 6).

If the line voltage compensation is set to OFF the voltage limit will act as a percentage of output limit and the absolute voltage limit will change with line voltage.

## 4.8 Configuration Dipswitch

The configuration dipswitch is used for setting up the command input, line voltage compensation and soft. Using a pen point gently push the switch up for on and down for off according to the setup outlined in the table below.

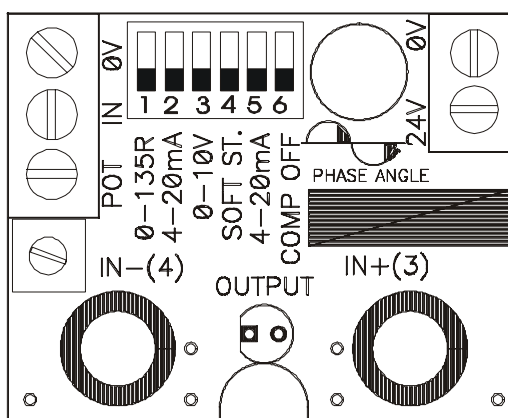

Command Input	1	2	3	5
<b>0-5V (Default)</b>	OFF	OFF	OFF	OFF
<b>Potentiometer</b>	OFF	OFF	OFF	OFF
<b>0-10V</b>	OFF	OFF	<b>ON</b>	OFF
<b>4-20mA</b>	OFF	<b>ON</b>	OFF	<b>ON</b>
<b>1-5V</b>	OFF	OFF	OFF	<b>ON</b>
<b>2-10V</b>	OFF	OFF	<b>ON</b>	<b>ON</b>
<b>0-135Ω*</b>	<b>ON</b>	OFF	OFF	OFF
<b>PWM**</b>	OFF	OFF	OFF	OFF

\*Module must be ordered as LPC-135 for 0-135Ω input support.

\*\*Module must be ordered as LPC-PWM for PWM input support

Feature to Enable	4	6
<b>Line Voltage Comp Enabled (default)</b>	OFF	OFF
<b>None</b>	OFF	<b>ON</b>
<b>Soft Start Only Enabled</b>	<b>ON</b>	<b>ON</b>
<b>Soft Start &amp; Line Voltage Comp Enabled</b>	<b>ON</b>	OFF

### 4.9 Control Output

The LPC SSR output drive is a DC pulsed current limited 10V/15mA (nominal) drive signal. This is more than enough current for driving most 3-32V standard SSRs, however it is still important to review the data sheet for the SSR you would like to use for compatibility with the LPC's output drive. The control output can tolerate a momentary direct short. The following graph will allow you to verify the SSR's compatibility with the LPC over wide input voltage variations.

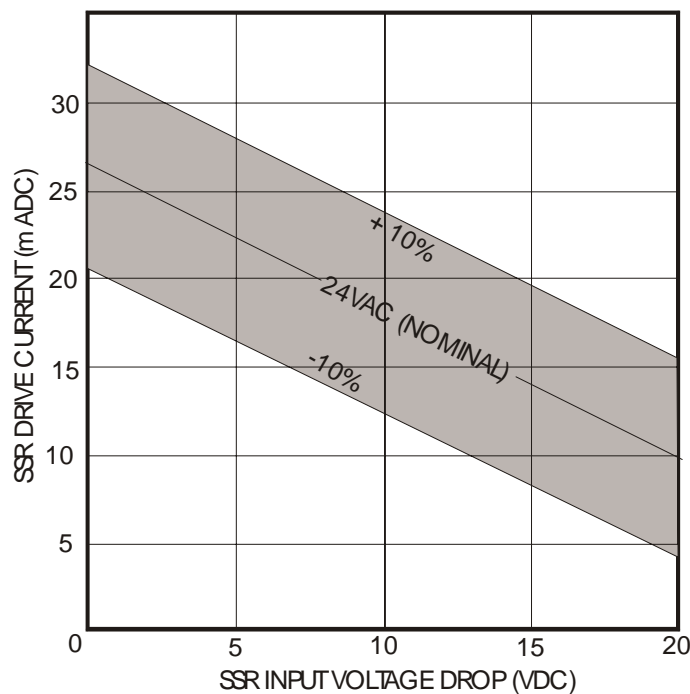

LPC Output Drive Current vs. SSR Input Voltage Drop

#### 4.10 Output LED

The LPC's RED output LED will turn on when the output is on and increase in intensity as the power output is increased. Because the drive signal varies considerably to give linear power output, the LED should only be used as a rough indication of SSR Drive and not actual power output. The output LED is wired in series with the SSR's input. If there is a poor connection on the SSR input terminals or a problem with the SSR's Input, the output LED will not become energized.

#### 4.11 Three Phase Operation

Three LPCs can be used to control three poles of a three phase load for inside delta or grounded wye configurations. The Module should be wired as shown in the wiring diagrams, using one transformer for each leg to be controlled.

##### 4.11.1 Three Phase Special Wiring Considerations

The LPC derives its AC synchronization from the applied 24VAC power. Each 24VAC transformer's primary must be connected to the corresponding leg power to be controlled by each LPC.

##### 4.11.2 Three Phase Wiring of Command Inputs

The command inputs should be connected in parallel if 0-5V or 0-10V is selected and in series if 4-20mA is selected.

#### 4.12 Wiring Multiple Units in Single Phase Applications

If more than one LPC is to be used from a non-isolated or common command signals:

1. A common power transformer can be shared. If the input selected is 0-10V or 0-5V, the inputs should be wired in parallel.

2. If multiple units must be powered from one power transformer and 4-20mA input is selected, one module should be set for 4-20mA and the remaining modules should be set for 1-5V.
3. If the command is 4-20mA, and the command inputs are to be wired in series, a separate power transformer for each module is required to isolate the inputs.

#### 4.12.1 Connecting Power & Commands In Parallel

When multiple LPC power inputs and commands are wired in parallel, all of the 0V terminals must be connected together follows:

Power:	Command:
0V-----0V-----0V----->	0V-----0V-----0V----->
24V---24V---24V--->	IN-----IN-----IN----->

No crossing of the power input feed or command signal is permitted. Command inputs are not isolated from the 24VAC power Input. If for some reason the power should become crossed, it will cause a direct short in the system. If properly fused, the fuse will blow and the LPC will not be damaged. If the command inputs are wired improperly, damage to LPC can result.

We do not guarantee operation of the LPC with any other manufacturer's SSR control module. Using them in the same circuit may cause either module to be damaged.

## 5. Electrical Specifications

Command Inputs	4-20mA, 0-10V, 0-5V, 0-135 $\Omega$ , Pot, PWM
Input Impedance	10K $\Omega$ (0-10V), 250 $\Omega$ (4-20mA), 100K $\Omega$ (0-5V)
0-135 $\Omega$ Excitation Current	13mA max
Control Output	SSR Drive, DC pulse, nominally 10V at 15mA
Response Time	50mS
PWM Input Period Range	1-5 Seconds
PWM Input Level	5-30VDC
Output Linearity	+/-2%
External Potentiometer Res.	1K $\Omega$ -25K $\Omega$
Line Voltage Comp. Range	+15%/-15% up to 100% output
Regulation	2%
Soft Start Period	20 Seconds to reach 100% output
Voltage Limit Range	5-100% of max load voltage.
Ambient Temperature Range	0 to 70 $^{\circ}$ C
Power Supply	24VAC +15/-15%, Power consumption less than 2 Watts
Line Frequency Range	47-63 Hz

## 6. Mechanical Dimensions



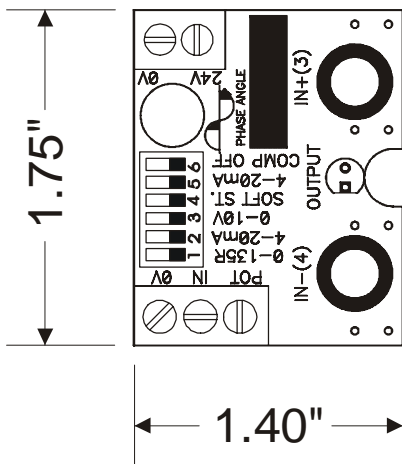

Max Height is 0.6"

### 7. Contact Information

HBControls, Inc  
 221 Weaver St  
 Fall River, MA  
 02720  
[www.HBControls.com](http://www.HBControls.com)  
 (800) 879-7918

### 8. WIRING DIAGRAM (4-20mA, 0-5V, 0-10V Inputs)

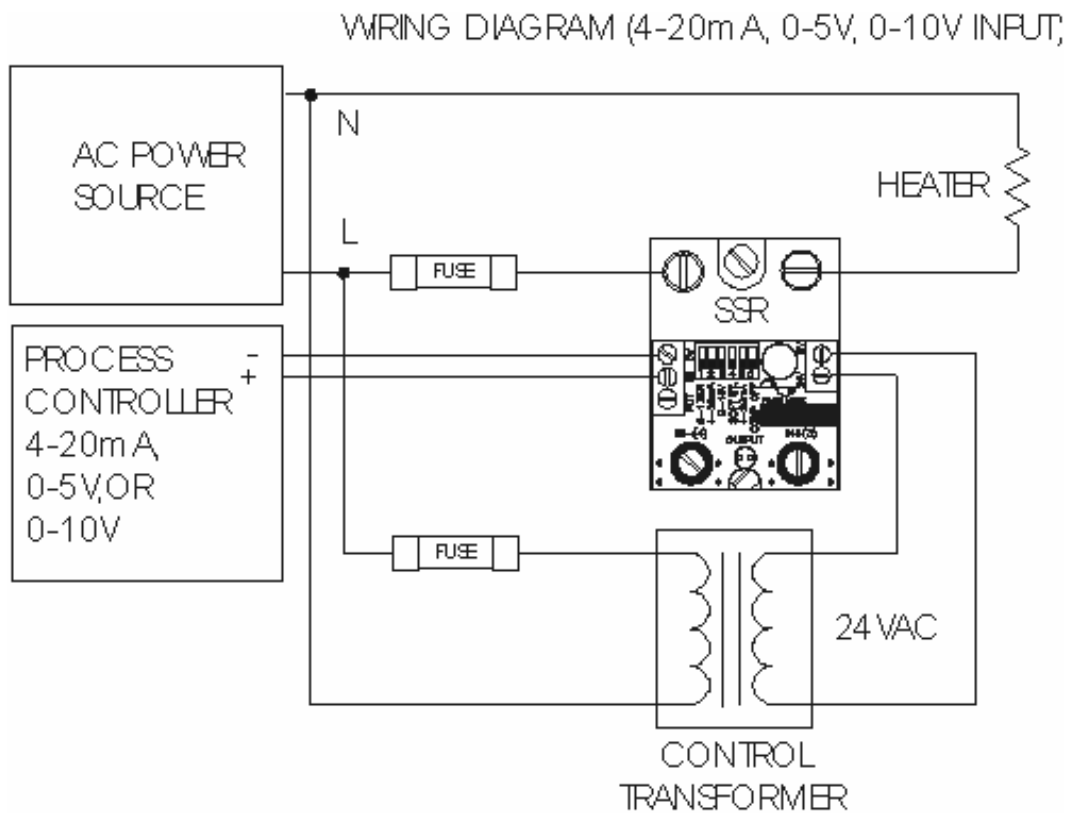

### 9. WIRING DIAGRAM (Potentiometer Input)

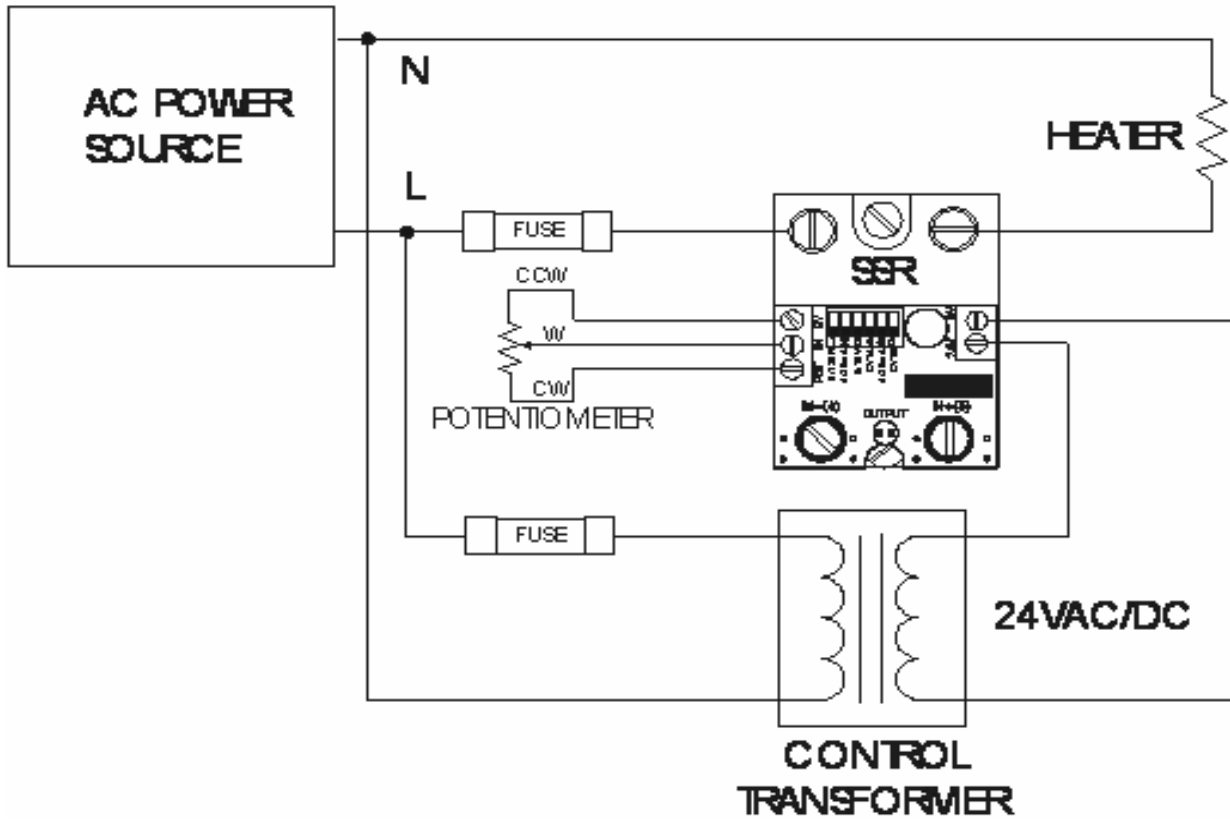

### 10. WIRING DIAGRAM (0-135 Ohm Input)

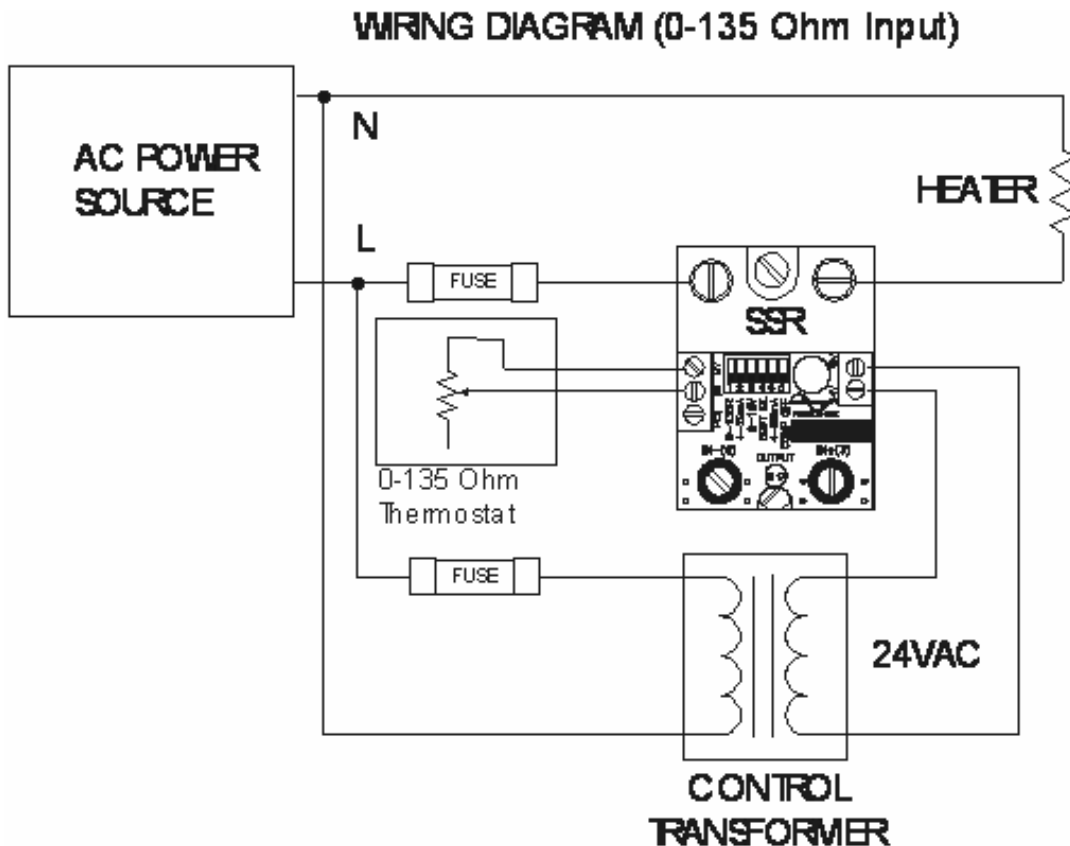

### 11. WIRING DIAGRAM (PWM Input)

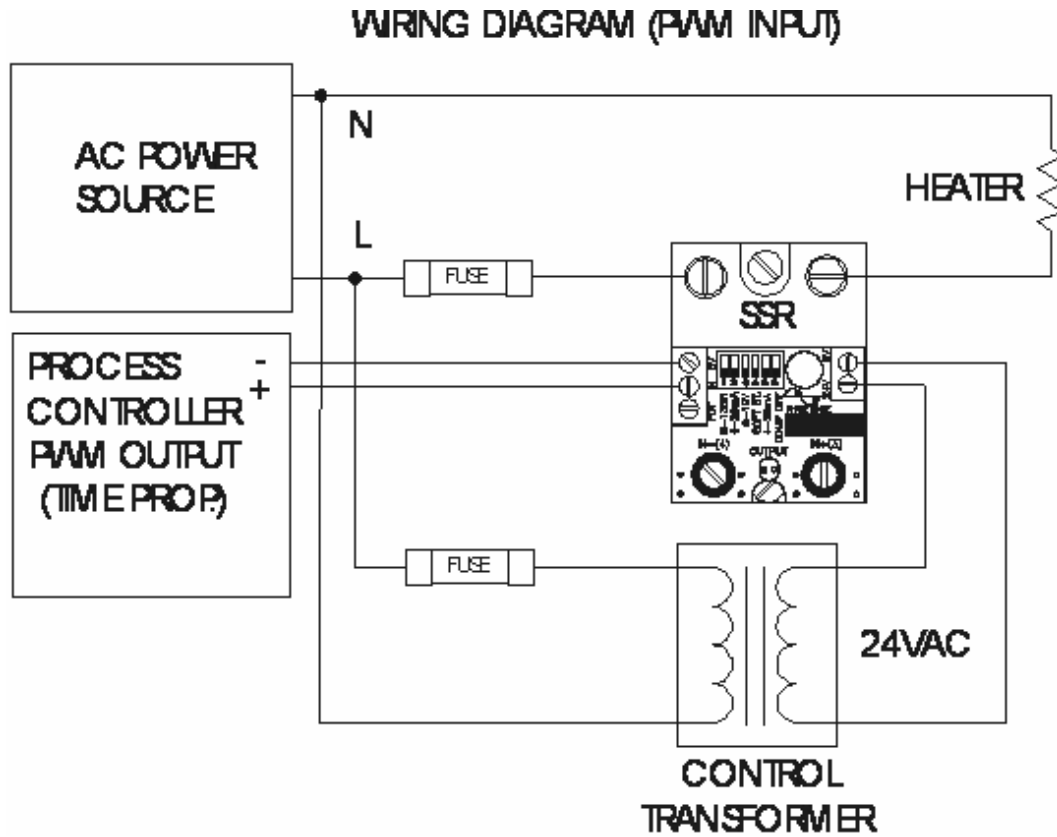

### 12. WIRING DIAGRAM 3 PHASE 4 WIRE Y CONNECTION

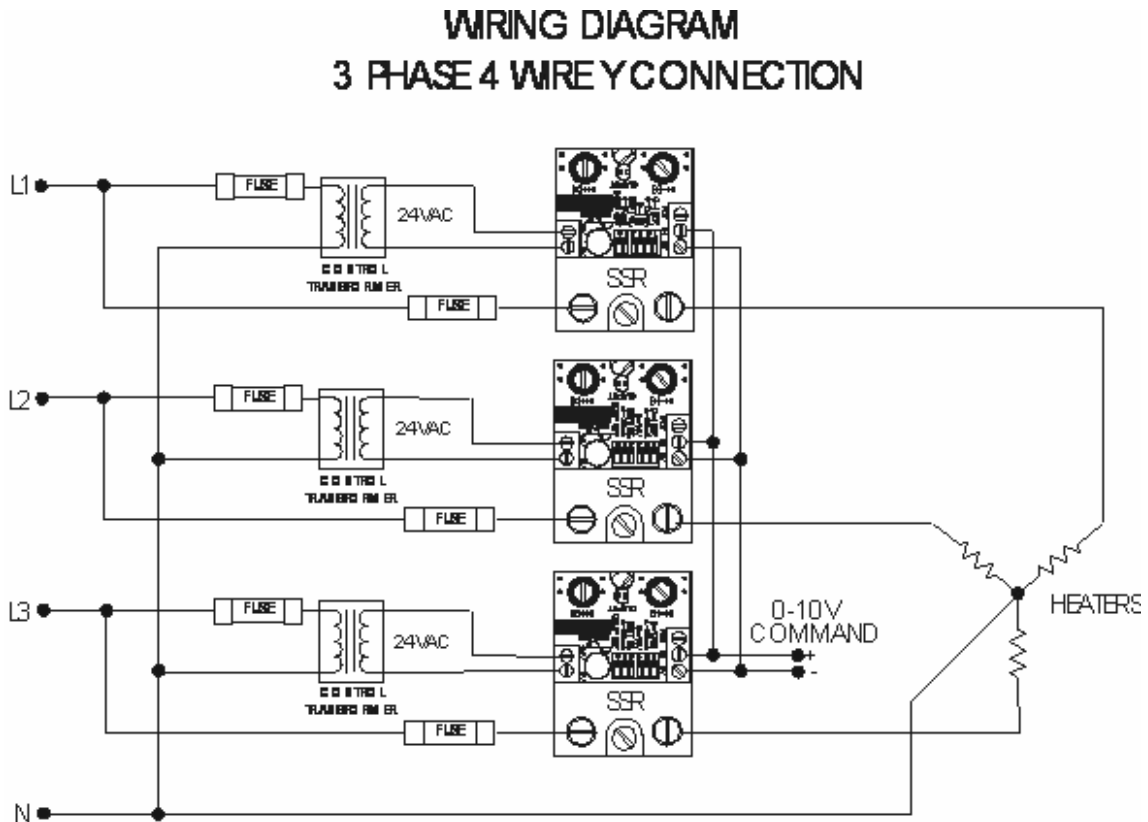

### 13. WIRING DIAGRAM 3 PHASE INSIDE DELTA

